

Yacht Devices

User Manual

NMEA 0183 Multiplexer YDNM-02

Firmware version

1.05

2024

© 2019 Yacht Devices Ltd. Document YDNM02-002. March 20, 2024. Web: <http://www.yachtd.com/>

NMEA 2000® is a registered trademark of the National Marine Electronics Association. SeaTalk NG is a registered trademark of Raymarine UK Limited. Garmin® is a registered trademark of Garmin Ltd.

Contents

Introduction	4
Warranty and Technical Support	5
I. Product Specification	6
II. NMEA 0183 Basics	8
III. Installation and Connection of Device	10
IV. LED Signals	13
V. Selecting Presets and Settings Reset	15
VI. Routing and Data Filters	16
VII. Device Configuration with NMEA 0183 Commands	19
VIII. Firmware Update	28
APPENDIX A. Troubleshooting	30
APPENDIX B. Configuration Presets	32
APPENDIX C. Conversions Between SeaTalk and NMEA 0183	38

Package Contents

Device	1 pc.
This Manual	1 pc.
Screws	2 pcs.
Paperclip for reset	1 pc.

Introduction

The NMEA 0183 Multiplexer (hereinafter Multiplexer or Device) is a configurable NMEA 0183 and SeaTalk multiplexer. The Multiplexer has six configuration presets with different port speeds and routing schemes. Presets can be selected by pressing the Device's hidden button (a paper clip is required, supplied with the Device). This makes installation very easy: select a suitable preset from Appendix B and set it up with a few clicks!

The Multiplexer has five physical NMEA 0183 ports (five inputs and three outputs) with configurable speed from 300 to 115200 baud. This allows organization of data exchange between multiple Devices with different speeds. Multiple physical listeners can be connected to the Multiplexer's outputs. Port #4 is galvanically isolated and has five terminals: four data terminals (TX+, TX-, RX+, RX-) and a dedicated ground (also isolated from other ports and Multiplexer's ground).

The Device is supplied with preset #1 activated (its settings are printed on the Device's case). In this preset three of the five NMEA 0183 ports are configured for automatic port speed detection. This means that in most cases you need not worry about the speed of the NMEA 0183 equipment that you connect. Port #2 is configured to filter out outgoing AIS messages, to prevent occasional flooding of this port configured for 4800 baud speed.

Device also can filter data, restore missing NMEA 0183 sentences checksums or multiplex any messages «as is» (e.g. Navtex messages) when tunnel feature is enabled.

SeaTalk is a proprietary binary protocol of Raymarine company. It allows co-existence of multiple Devices on the bus, so the Multiplexer has only one SeaTalk port. A bi-directional converter between SeaTalk and NMEA 0183 supports all known SeaTalk datagrams, including autopilot (see Appendix C for details). This allows controlling SeaTalk autopilots from NMEA 0183 chart plotters and marine apps.

To change settings of configuration presets or update Multiplexer's firmware, you need a laptop or PC with either a serial (COM) port or USB-to-COM adaptor. You can configure physical ports speed, set up routing between ports and define data filters to reduce traffic on low-speed ports with special NMEA 0183 commands described in Sections VI and VII.

Thank you for purchasing our product and happy voyages!

Warranty and Technical Support

1. The Device warranty is valid for two years from the date of purchase. If the Device was purchased in a retail store, the sales receipt may be requested when applying for a warranty claim.
2. The Device warranty is terminated in case of violation of the instructions in this Manual, case integrity breach, or repair or modification of the Device without the manufacturer's written permission.
3. If a warranty request is accepted, the defective Device must be sent to the manufacturer.
4. The warranty liabilities include repair and/or replacement of the goods and do not include the cost of equipment installation and configuration, or shipping of the defective Device to the manufacturer.
5. Responsibility of the manufacturer in case of any damage as a consequence of the Device's operation or installation is limited to the Device cost.
6. The manufacturer is not responsible for any errors and inaccuracies in guides and instructions of other companies.
7. The Device requires no maintenance. The Device's case is non-dismountable.
8. In the event of a failure, please refer to Appendix A before contacting technical support.
9. The manufacturer accepts applications under warranty and provides technical support only via e-mail or through authorized dealers.
10. The contact details of the manufacturer and a list of the authorized dealers are published on the website: <http://www.yachtd.com/>.

I. Product Specification

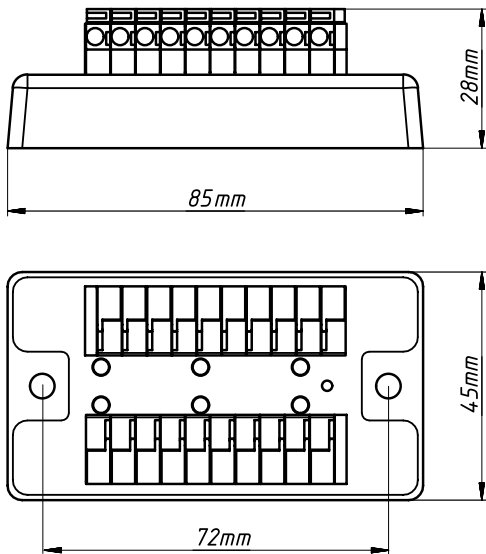

Figure 1. Drawing of Multiplexer

Device parameter	Value	Unit
Supply voltage	7..16	V
Current consumption, maximum, all ports with 100 Ohm load	60	mA
NMEA 0183 ports (inputs / outputs)	5 / 3	—
SeaTalk 1 ports	1	—
Receiver input resistance (port #1, #2, #3, #5 / port #4)	12 / 96	kOhm
Galvanic isolation of NMEA 0183 port #4	2500	V _{RMS}
Device case dimensions (LxWxH)	85x45x28	mm
Weight	80	g
Operating temperature range	-20..55	°C



Yacht Devices Ltd declares that this product is compliant with the essential requirements of EMC directive 2004/108/EC.



Dispose of this product in compliance with the WEEE Directive or local regulations. Do not dispose of it with household or industrial waste.

II. NMEA 0183 Basics

The default speed of a NMEA 0183 interface is 4800 baud. High-speed interfaces are 38400 baud and were designed especially for AIS, but usually chart plotters and instrument displays allow any data (not only AIS) on a high-speed port. On a chart plotter, port speed can be configured in the settings. NMEA 0183 uses different wires for talking (transmitting, TX) and listening (receiving, RX) data.

One talker can be connected to multiple listeners, but a listener can have only one talker connected. The Device can act as a «multiplexer» and join the output of multiple physical talkers to a single data stream.

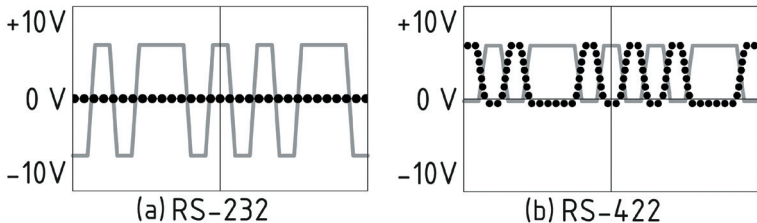

Figure 2. (a) RS-232 and (b) RS-422

NMEA 0183, until version 2.0 (1992), used a «single ended» RS-232 interface with one TX line and one RX signal line (grey at Figure 2.a) and ground line (dotted at Figure 2.a) used as reference for TX and RX signals. Therefore, old Devices have only three wires.

Since Version 2.0, NMEA 0183 has been based on a «differential» RS-422 interface, which has two RX lines RX+ (can also be marked as «A») and RX- (or «B»), two TX lines TX+ (or «A», grey at Figure 1.b) and TX- (or «B», dotted at Figure 2) and a ground (not shown at Figure 2.b). Modern Devices use five wires.

Devices of different versions can be connected, but with one cautionary note. TX- («B») is not equal to a ground line. Voltage on the TX- line (dotted on Figure 2.b) changes from 0 to 5V, and connecting this line to ground line can cause a short circuit.

The correct connection schemes are shown in Figure 3.

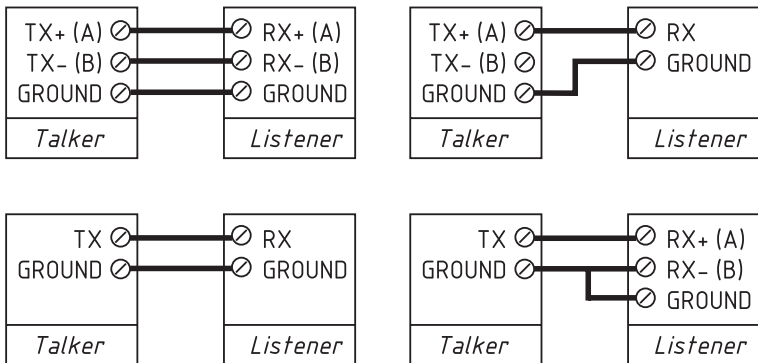

Figure 3. Connection of NMEA 0183 Devices

III. Installation and Connection of Device

The Device requires no maintenance. When deciding where to install the Device, choose a dry mounting location. Despite the fact that the Multiplexer case is waterproof, the terminals are open and seawater can cause a short circuit. Do not place the Device where it can be flooded by water, get wet in the rain or be sprayed with water.

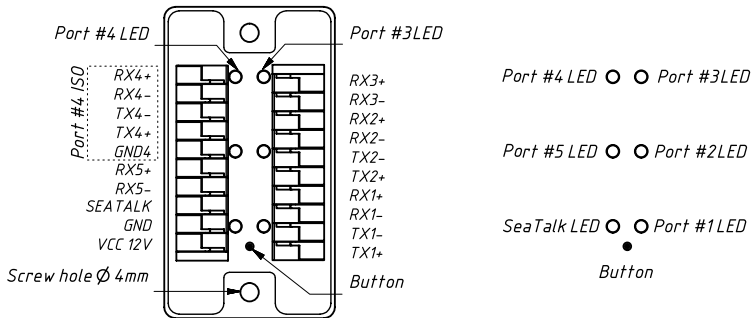

Figure 4. Multiplexer wire terminals (left) and LED's scheme (right)

The Multiplexer can be fixed horizontally or vertically using the two screw holes (4 mm diameter, 72 mm between centers) and the screws supplied. When the holes of wire terminals are pointing to the sides, they are better protected from occasional water spray.

The Multiplexer requires a DC power source from +7 to +16 V, which should be connected to its VCC (positive) and GND (negative) terminals (see Figure 1). It can be also powered from a SeaTalk bus (see below).

All connections should be made when the power is off. This will protect against accidental short circuits during installation. When the power and ground wires are connected, turn on the power supply and the Device's LEDs will blink (see the next Section).

1. NMEA 0183 equipment connection



The connection to the NMEA 0183 network varies depending on the version of the connecting equipment. Please, refer to Section II for connection schemas. The wrong wiring can damage the equipment!

The Multiplexer is supplied with five NMEA 0183 ports: two bidirectional (#1 and #2), one bidirectional and fully galvanically isolated (#4), and two input-only ports (#3 and #5). By pressing a hidden button on the Device you can select one of 6 user-configurable presets with different port speeds and data routing settings. In factory configuration, preset #1 is activated (refer to Appendix B), its factory settings are printed on the Devices' case.

Please note that bi-directional port #1 is configured for automatic speed detection. This means, that until data is received from this port, the Device will not send data to it, because the port speed is unknown. Detections starts from 4800 bps speed, and in the worst case the first sentence from the port will not be received correctly.

The only known type of equipment which may not work well with automatic speed detection is VHF DSC, which sends only messages about DSC calls and needs in GPS position, it is unknown when VHF DSC sends its first message.

The ground wire of high-speed ports (38400 bps) should be connected to the Multiplexer's ground terminal. In case of connection to isolated port #4, the ground wire of the equipment should be connected to the dedicated ground terminal of port #4 («GND4» at Figure 4).

2. SeaTalk bus connection

A SeaTalk bus has three wires: 12-Volt power supply (red label on equipment, red lead within a SeaTalk cable), ground (white or grey label on equipment, bare shield within a SeaTalk cable) and data (yellow label, yellow lead within a cable).

The Multiplexer can also be powered from the SeaTalk bus: ground and power supply wires of the SeaTalk bus should be connected to the Multiplexer's VCC and Ground terminals on the left side (see Figure 1), the data wire should be connected to the «SeaTalk» terminal on the Multiplexer's left side. In case of powering of the Multiplexer from another source, the ground wire of the SeaTalk bus should be connected to the Multiplexer's ground terminal (GND) on the left side.

IV. LED Signals

The Device is equipped with six bi-color port LEDs (SeaTalk port and NMEA ports #1–#5 — see Figure 4 above).

1. Signals during the power-on or preset change

At power-on or upon the preset change all LEDs light up for a few seconds depending on the configured port speeds: the corresponding port LED will be green if the port speed is set to 4800, red otherwise. The SeaTalk port speed is always set to 4800 baud and the corresponding port LED should be green.

Next, the single red LED lights up, indicating the current preset number (ports #1–#5 LEDs correspond to presets #1–#5, SeaTalk port — to preset #6).

Then all LEDs light up for a few seconds again, depending on the configured port speeds: the corresponding port LED will be green if the port speed is set to 38400, red otherwise. SeaTalk port LED should be red. Ports configured for automatic speed detection will blink RED in both cases.

After this sequence the LEDs start flashing in normal operation mode.

2. Signals during normal operation

During normal operation, the Device produces a series of four flashes of each port LED every ten seconds (counter-clockwise in direction, in the following order: port #1, #2, #3, #4, #5, SeaTalk). The flashes indicate the state of the Device interfaces over the last ten seconds and have the following meaning:

- **Port LED, flash #1: data received.** Green, if any data was received by this port in the last 10 seconds (even if they were filtered out later, see the Section VI).
- **Port LED, flash #2: RX errors.** Green, if any data was received and all data was received without errors. NMEA 0183 sentences contain a checksum, so any transmission error will be detected.

- **Port LED, flash #3: data sent.** Green, if data was sent from this port. As there is no confirmation of reception, this signal does not mean that data was received by any listener. Red means that the Multiplexer has nothing to send.
- **Port LED, flash #4: TX overflow.** Green, if data was sent without overflow. In case of a red signal, you should increase the port speed (if possible) or filter out unnecessary data, because the selected speed is not enough to send all the data. This signal will also be red if flash #3 is red.

3. Signals during Device reset

LED signals during Device reset are described in Section V.

4. Signals during firmware update

LED signals during firmware update procedure are described in Section VIII.

V. Selecting Presets and Settings Reset

1. *Selecting a preset*

The Multiplexer has 6 user-configurable presets with different routing schemes and port speeds (see Appendix B). Insert the paper clip into the small hole near the SeaTalk LEDs (see the button location at Figure 4) and briefly press it to activate the next preset. Port speeds and current preset number will be indicated by Multiplexer's LEDs according to Section IV.1.

Any preset can be later modified with configuration commands (see Section VII.1). To return to the default factory settings, perform a settings reset.

It is also possible to disable/enable the preset selection function of a button using a configuration commands (see Section VII.4). If the preset selection function is disabled, the Device's button can only reset the Device's settings to a factory default.

2. *Settings reset*

To reset the Device to a factory configuration, press and hold the hidden button. Port #1's LED will shine red. Wait 10 seconds and the port #1 LED will change from red to green. Release the button while the LED is green to reset the Device's settings. Reset is confirmed by the Device with a power-on LED sequence with active routing preset #1 (see Section IV.1). If you keep pressing the button, the LED will become red 2–3 seconds later. If you release the button while the LED is red, Device will not perform a reset.

VI. Routing and Data Filters

1. Routing

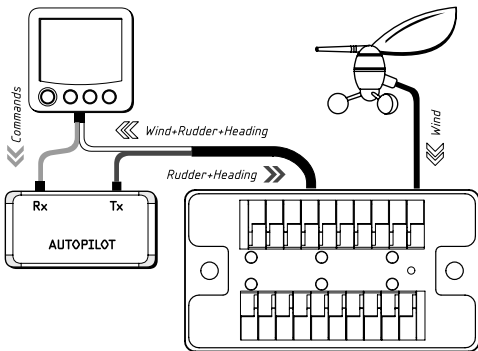

Figure 5. In-line connection

Different Devices can be connected to the input and output wires of the same port of the Multiplexer. In this case you may need to specify that this port is the output for itself (available in presets #4 and #6). This also allows connecting the Multiplexer «in-line» with two Devices (see Figure 5) to enrich the data stream with data from other ports.

Old NMEA 0183 equipment or software may send NMEA 0183 sentences with no checksum. By default, Device ignores sentences with no checksum, they will be dropped. You can enable checksum restoration for

received sentences (see VII.1, RTE command).

You can also enable tunneling for non-NMEA 0183 data, for example Navtex equipment. In this case, received data will be forwarded «as is» and will not be processed by filters.

Invalid sentences are not processed by incoming filters or outgoing filters. Correct sentences are always processed by filters, whether tunneling is off or on.

2. Data filters

The Device has 20 filters, which allow limiting the set of incoming or outgoing sentences on each port. Each port has four filter lists: two for incoming NMEA 0183 sentences (one for sentence formatters and one for the talker ID), and two the same for outgoing sentences (except for ports #3 and #5 which have no physical outputs).

The filter set is global, meaning that it is not tied to a preset. If you change the active preset the filters will not be changed.

Each filter list has a switchable type: WHITE or BLACK. A message is passed through the WHITE filter if it contains a record matched with a message. And the reverse for BLACK. In the factory settings, all filter lists (with one exception) are empty and are of BLACK type, so all messages are passed through the filters.



The only exception is port #2 which filters out outgoing AIS messages (VDO and VDM) to prevent flooding of low speed equipment connected to this port.

According to the standard, an NMEA 0183 sentence starts with a \$ or ! symbol, followed by a two-character talker ID and a 3-char sentence formatter. These elements are followed by data fields (after the comma). The sentence is finished by a checksum after the * (asterisk) symbol.

The following sentences matches to GLL and VDM records in the sentence filter or GP and AI records in the talker ID filter:

```
$GPGLL,4146.5894,N,07029.6952,W,173412.02,A*15  
!AIVDM,1,1,,B,ENk`smq71h@@@@@@@@@@@@@@@@=MeR6<7rpP00003vf400,4*5F
```

The Talker ID filter contains 2-char talker IDs separated by a space character, and sentence filters contain 3-char NMEA 0183 sentence formatters separated by a comma character. Example of sentences and talker IDs filters:

- GLL,VDM,VDO
- GP,AI

Filters allow reduction of the port load. If the fourth flash of the port's LED indicates overflow (see Section IV.2), unnecessary messages can be excluded using the transmit filter of this port.

The Multiplexer has a bi-directional converter between SeaTalk and NMEA 0183. On the Seataalk port you can use NMEA 0183 filters and datagram filters («Sxx», where xx is a hexadecimal datagram number, see Appendix C). For example, NMEA 0183 water temperature MTW sentence is converted to Seataalk datagrams 23 and 27 (hexadecimal). To prevent sending water temperature to or from SeaTalk, you can specify the sentence filter «MTW» (temperature will be filtered out at NMEA 0183 level) or «S23 S27» (will be filtered at datagram level).

In case of a WHITE filter on the SeaTalk port, you should specify «MTW S23 S27» to allow water temperature processing because you need allow processing of SeaTalk datagrams 23 and 27 and generation of MTW sentence.

Configuration procedures for setting the routing scheme and data filters are given in the next Section.

VII. Device Configuration with NMEA 0183 Commands

If none of the factory routing schemes and baud rate presets (given in Appendix B) satisfies your equipment requirements or you need to set up data filtering (see VI), you will need to configure the Multiplexer by sending a special NMEA 0183 sentences to any port from #1 to #5. The Multiplexer will reply to the commands on the same port they were received, thus you cannot get a reply on ports #3 and #5 as they are input-only.

Connect the Multiplexer to a serial port of a PC either directly or with a COM-to-USB adaptor. You will need an RS-232 or RS-485/RS-422 compatible COM-to-USB Adaptor. RS-422 adapter is highly recommended.



Connect hardware serial ports or RS-232 COM-to-USB adaptor only to the isolated port #4 to avoid port damage due to ground potential difference. Note that on some RS-422 adapters the signal line «A» may be wrongly labeled as «-» and «B» as «+».

Use a COM-port terminal application like PUTTY (free download at www.putty.org) to enter and send the NMEA 0183 configuration commands. Configure the COM-port baud rate in a terminal application to match the current port baud rate setting, set the number of data bits to 8, number of stop bits 1, disable parity check. If you have sent the command to change the port baud rate to the Multiplexer, you should reconnect the terminal application using a new port baud rate.

When using a terminal application which sends data immediately upon enter, it is recommended to type the command first in a text editor and then copy the whole string to a terminal.



Configuration commands do not require a correct NMEA 0183 checksum, two zero characters (00) can be used. However, if you send commands through other NMEA 0183 equipment like a third-party multiplexer, you will need to enter a valid checksum. You can use, for example, an online NMEA 0183 checksum calculator.

Note that configuration commands \$YDMPX are always received by Device and cannot be blocked by filters or other settings.

1. Port speed and routing scheme setting commands

`$YDMPX,p,BPS,b*cc`

p – port number 1..5;

b – baud rate;

cc – valid NMEA 0183 checksum or 00.

The BPS command sets the baud rate for specified port. Supported baud rates are 300, 1200, 2400, 4800, 9600, 19200, 38400, 57600, 115200 or AUTO. With AUTO setting, the port baud rate will be automatically determined by the Device upon valid NMEA 0183 data reception. Supported baud rates for AUTO mode are 4800, 9600 and 38400. In AUTO mode, the Device will not output data on the corresponding output port with until the baud rate is determined.

Example 1: `$YDMPX,5,BPS,38400*3F` – set the port #5 baud rate to 38400 baud.

Example 2: `$YDMPX,1,BPS,AUTO*0B` – set the port #1 baud rate to be automatically determined by Device.

`$YDMPX,p,RTE,f,c,out1[,out2[,...]]*cc`

p – input port number 1..5 or S for SeaTalk port.

f – tunneling flag, T = tunneling is enabled, empty field if disabled;

c – no-checksum-restore-flag, C = add checksum to sentences with no checksum and enable sentences conversion, empty field if disabled;

outN – comma separated list of output ports, numbers 1 - 5 or S for SeaTalk port;

cc – valid NMEA 0183 checksum or 00.

The RTE command sets the routing scheme from an input port to multiple output ports for the current preset and modifies the tunneling setting for input port.

Example 1: `$YDMPX,4,RTE,T,,1,2,5*61` – forward port #4 input data to ports #1,#2 and #5 and enable tunneling of messages, received on port #4.

Example 2: `$YDMPX,4,RTE,,C,1,2,5*76` — forward port #4 input data to ports #1,#2 and #5 and disable tunneling of messages, received on port #4; restore checksums of all NMEA 0183 sentences received on port #4.

Example 3: `$YDMPX,4,RTE,,*2F` — disable forwarding of all messages, received on port #4.

`$YDMXR,p,CFG,b,f,out1[,out2[,...]]*cc`

p — port number 1..5 or S for SeaTalk port.

b — current baud rate;

f — tunneling flag, T = tunneling is enabled, empty field if disabled;

outN — comma separated list of output ports, numbers 1 - 5 or S for SeaTalk port;

cc — valid NMEA 0183 checksum.

The CFG reply sent in reply to BPS and RTE commands described above. No reply means that command is wrong or was not received by the Device. See VII.3 for the description of CFG reply with Device's settings (D in the first parameter).

2. Filter setting commands

`$YDMPX,p,FLS,d,o[,fmt[,...]]*cc`

p — port number 1..5 or S for SeaTalk port;

d — R for incoming sentences, T for outgoing sentences;

o — operation code (W,B,A or R);

fmt — comma separated list of 3-char NMEA sentence formatters or SeaTalk datagrams;

cc — valid NMEA 0183 checksum or 00.

The FLS command modifies the filter for NMEA 0183 sentence formatters (see VI.2) or SeaTalk datagrams on specified port number. SeaTalk datagrams should be in the form «Sxx», where xx is a hexadecimal datagram number (see Appendix C).

The meaning of the command depends on the operation code:

- W: set filter type WHITE and replace filter's formatters by specified;
- B: set filter type BLACK and replace filter's formatters by specified;
- A: add specified formatters to the filter;
- R: remove specified formatters from the filter.

Example 1: `$YDMPX,4,FLS,T,B,VDM,VDO*21` — disables output of AIS sentences (VDM and VDO) on port #4.

Example 2.1: `$YDMPX,1,FLS,T,W,HDG,HDT*20` — enables output of only HDG and HDT sentences on port #1.

Example 2.2: `$YDMPX,1,FLS,T,A,HDM*48` — adds HDM to the filter list configured by a command in the previous example (2.1). Now HDG, HDM and HDT are allowed on output of Port#1.

Example 2.3: `$YDMPX,1,FLS,T,R,HDT*42` — removes HDT from the filter list configured by a command in the previous example (2.3). Now only HDG and HDM are allowed on the Port#1 output.

Example 2.4: `$YDMPX,1,FLS,T,B*26` — changes the filter type to BLACK, leaving the sentence formatters list intact. Now HDG and HDM are disabled on the Port#1 output.

Example 3: `$YDMPX,1,FLS,T,W,*1F` — sets the filter type to WHITE and clears filter formatters list (formatters list is present, but empty).

Example 4: `$YDMPX,S,FLS,R,W,S00,DBT*56` — enable receive only depth datagram from SeaTalk port and enable conversion only to DBT NMEA 0183 sentence (by default, datagram 00 is converted to both DBT and DPT sentences, but we enabled only DBT).

`$YDMXR,p,FLS,d,t[,fmt[,...]]*cc`

t — filter type, B for BLACK, W for WHITE;

cc — valid NMEA 0183 checksum;

other parameters are the same as in command FLS described above.

The reply FLS sent in reply to FLS command. Contains actual sentence formatters and SeaTalk datagrams filter configuration.

\$YDMPX,p,FLT,d,o[,tk[,...]]*cc

p — port number 1..5;

tk — comma separated list of 2-char NMEA 0183 talker ID's;

other parameters the same as in FLS command described above.

The FLT command sets the filter for NMEA 0183 talker IDs (see VI.2) in the same way, as FSL set the filter for sentence formatters. To be passed through, the incoming or outgoing message must pass both sentence and talker ID filters.

Example 1: \$YDMPX,1,FLT,R,W,GP*09 — enables reception only of sentences from a GPS receiver (with «GP» talker) on Port #1.

Example 2.1: \$YDMPX,2,FLT,T,W,AI,GP*28 — enables output of only AIS sentences (with «AI» talker) and GPS sentences (with «GP» talker) on Port #2.

Example 2.2: \$YDMPX,2,FLT,T,R,GP*09 — removes «GP» talker from the filter list configured by a command in the previous example. Now only sentences from AIS receiver are allowed on Port#2 output.

Example 2.3: \$YDMPX,2,FLT,T,B*22 — changes filter type to black, leaving the sentence formatters list intact. Now all sentences except AIS sentences (from «AI» talker) are allowed on Port#2 output.

Example 4: \$YDMPX,2,FLT,T,B,*0E — sets filter to BLACK and clears talker ID list (talker ID list is present, but empty).

\$YDMXR,p,FLT,d,t[,tk[,...]]*cc

t — filter type, B for BLACK, W for WHITE;

cc — valid NMEA 0183 checksum;

other parameters are the same as in command FLT described above.

The reply FLT sent in reply to FLT command and contains actual talker ID filter configuration.

3. Get Device configuration commands

\$YDMPX,p,CFG*cc

p — port number 1..5 or S for SeaTalk port;

cc — valid NMEA 0183 checksum or 00.

The CFG command requests speed and routing configuration for a specified port. The Device answers with three sentences: CFG (see VII.1), FLS and FLT (see VII.2) replies.

\$YDMPX,D,CFG*5E or \$YDMPX,D,CFG*00

This form of CFG command (D in the first parameter) request Device configuration. The Device replies with CFG reply with D in first parameter (see below).

\$YDMXR,D,CFG,sn,fw_ver,PSn,tt,locked_flag,p*cc

sn — Device's serial number;

fw_ver — current firmware version with build date in dd/mm/yyyy format;

PSn — current preset number, from PS1 (preset #1) to PS6 (preset #6);

tt — current NMEA 0183 talker ID;

locked_flag — preset selection by button (L = disabled, empty field = enabled);

p — port number on which the reply output was produced — 1,2 or 4;

cc — valid NMEA 0183 checksum.

The reply CFG with D in the first parameter sent in reply to the Device's settings request described above. See also VII.1 for the format of CFG reply with port's settings data.

Note: when the Device is powered on, it sends this reply to all ports once.

\$YDMPX,A,CFG*5B or \$YDMPX,A,CFG*00

The command CFG with A in the first parameter requests the Device's full configuration. The reply contains multiple sentences:

- CFG reply with Device's settings (described above);
- six CFG replies with settings (speed, routing, tunneling) for all six ports (see VII.1);
- six FLS and five FLT replies (except SeaTalk port) with filters of all six ports (see VII.2).

\$YDYDQ,VER*3C

This standard NMEA 0183 request returns the current firmware version and Device serial number.

Reply: \$YDVER,1,1,MX,00717,,sn,YDNM-02,fw_ver,hw_ver,n*cc

00717 — Yacht Devices NMEA 2000 manufacturer code;

sn — Device's serial number;

fw_ver — current firmware version with build date in dd/mm/yyyy format;

hw_ver — Device's hardware version;

n — message sequential number (from 1 to 9, increments with each VER sentence sent);

cc — valid NMEA 0183 checksum.

Reply example: \$YDVER,1,1,MX,00717,,00090103,YDNM-02,1.01 04/03/2019,1.0,1*6F

— Device serial number is 00090103, firmware version 1.01 with build date 04 of March 2019, hardware version 1.0.

4. Device control commands

\$YDMPX,D,PSn*cc

PSn — preset number, from PS1 (preset #1) to PS6 (preset #6);

cc — valid NMEA 0183 checksum or 00.

Commands PS1..PS6 activate the specified preset. The Device responds with the power-on LED indication sequence (see IV.1). Reply is the same as for CFG command (see VII.3), but it may not be received

if the port speed in the new preset is different.

\$YDMPX,D,TID,tt*cc

tt – NMEA 0183 talker ID, two capital letters A–Z or two dashes (- -);

cc – valid NMEA 0183 checksum or 00.

The command TID sets the NMEA 0183 talker ID (factory setting is «YD») for outgoing NMEA 0183 sentences generated from the received SeaTalk datagrams. The reply is the same as for the CFG command (see VII.3).

\$YDMPX,D,STE*5E or \$YDMPX,D,STE*00

The STE command enables Device to generate \$STALK sentences which encapsulate raw SeaTalk 1 bus data. Might be needed for software that can use \$STALK sentences to gain direct access to SeaTalk 1 bus, for example, OpenCPN SeaTalk 1 autopilot plugin.

\$YDMPX,D,STD*5F or \$YDMPX,D,STD*00

The STD command disables Device to generate \$STALK sentences.

\$YDMPX,D,LCK*58 or \$YDMPX,D,LCK*00

The LCK command disables preset selection with the button. This protects against unintentional switching of the selected preset by a child or incompetent staff. The reply is the same as for the CFG command (see VII.3). Note that the `locked_flag` field in a reply should be set to L, indicating that the preset selection function of a button is disabled.

\$YDMPX,D,ULK*4E or \$YDMPX,D,ULK*00

The command ULK enables preset selection with the button. The reply is the same as for the CFG command (see VII.3). Note the `locked_flag` field in a reply – it should be empty, indicating that the preset selection function of a button is enabled.

\$YDMPX,p,RST*cc

p – port number 1..5 or S for the SeaTalk port.

cc – valid NMEA 0183 checksum or 00.

The RST command resets the specified port speed, routing settings and filters to a default factory configuration for the currently active preset. The reply is the same as for the CFG command (see VII.3).

\$YDMPX,D,RST*49

This form of the RST command (with D in first parameter and a valid checksum) resets all Device settings to the factory default. The Device responds with the power-on LED indication sequence (see IV.1).

VIII. Firmware Update

Firmware update requires a connection to a serial (COM) port of the PC (see Section VII). You can check the current firmware version by sending a `$YDMPX,D,CFG*5E` sentence to any port of the Device (see Section VII.3) or by receiving a `$YDMXR` sentence, which the Device sends to all ports when powered-on.

Device routing presets and filter configurations will not be affected by an update (unless otherwise stated in the README.TXT file provided with the update). You will not damage the Device in the event of power failure or any other shutdown at any point of the firmware update procedure.

To update the Multiplexer's firmware, first configure the COM port and set the number of data bits to 8, the number of stop bits to 1, and disable parity check. You should also check the connected Multiplexer's port baud rate setting (see VII.1) and set the baud rate corresponding to the connected port baud rate setting.



The maximum allowable baud rate for a firmware update is 38400 baud.

You can set up the serial port with the following commands from the operating system command line (shell). COM1 and `/dev/ttySO` in the following commands are examples of the hardware ports under Windows and Linux, while `/dev/cu.usbmodem00570001` is an example of a virtual serial port name created by USB-to-COM adaptor's driver under Mac OS X.



```
mode COM1 BAUD=4800 DATA=8 STOP=1 PARITY=n
```



```
stty -F /dev/ttyS0 4800 cs8 -cstopb -parenb hupcl
```

In Mac OS X it is recommended to set the port baud rate and send an update file with one command (see below).

To update Device firmware, you should copy the firmware file (XUPDATE.BIN) to the Device's port.

Note: the XUPDATE.BIN file should be located in the shell's current working directory.



```
copy /B XUPDATE.BIN COM1
```



```
cp XUPDATE.BIN /dev/ttyS0
```



```
stty -F /dev/cu.usbmodem00570001 4800 cs8 -cstopb -parenb hupcl &  
cp XUPDATE.BIN /dev/cu.usbmodem00570001
```

File uploading takes about 60–100 seconds, depending on the selected port speed. During the file upload, the corresponding port LED will rapidly flash GREEN (with 100 ms interval). Any file transfer error will be indicated by LED flashing RED with 100 ms interval until the file transfer stops.

After successful firmware file upload, all Device's LEDs will flash RED and GREEN with a 500 ms interval for 5 seconds. After that, the Device resets, produces a power-on LED indication sequence (see Section IV.1) and returns to a normal operation.

You can confirm a successful update by checking the firmware version (see Section VII.3).

APPENDIX A. Troubleshooting

Situation	Possible cause and correction
All LEDs are off	No power. Check the voltage between ground and power terminals, it should be 7–16 V. Check also the supply voltage polarity (see III).
Port LED indicates no data received (first LED flash is red)	<p>1. Incorrect wiring of the NMEA 0183 talker equipment connected to this port. Check the wiring according to the recommendations given in Section II. Refer to your NMEA 0183 talker equipment documentation to get the NMEA 0183 output wiring.</p> <p>2. Wrong baud rate. Refer to your NMEA 0183 talker equipment documentation and check which baud rates are supported and how to change it. Set the same baud rate on both NMEA 0183 talker equipment output port and the corresponding Multiplexer's port (see VII.1).</p>
Port LED indicates RX errors (second LED flash is red)	<p>1. Incorrect wiring of the NMEA 0183 talker equipment connected to this port. Check the wiring according to the recommendations given in Section II. Refer to your NMEA 0183 talker equipment documentation to get the NMEA 0183 output wiring.</p> <p>2. EMI interference. Check that the data cables are not affected by an EMI source, reroute the cable, use high-grade, shielded cable. Reduce the port speed if equipment allows it.</p>
Port LED indicates no data sent (third LED flash is red)	<p>1. Improper routing scheme, no data forwarded to this port. Check the current routing configuration (see VI.1).</p> <p>2. All outgoing NMEA 0183 sentences are blocked by filter. Check port filters configuration (see VI.2).</p>

Situation	Possible cause and correction
Port LED indicates an overflow (port LED flash #4 is red)	Too much data for output on this baud rate. Exclude unnecessary sentences on this port using filters. Increase the baud rate if the connected NMEA 0183 equipment supports it. Change the routing settings to exclude forwarding data from unnecessary ports.
Device does not change presets when the button is pressed	Preset selection by button is disabled. Enable it with the configuration command (see VII.4) or perform a settings reset (see V.2).
Multiplexer does not accept Navtex messages	Navtex messages do not comply with NMEA 0183 Standard. Turn on the tunneling (see VI.1) to pass-through Navtex messages.
Firmware update: file uploading fails constantly	Check PC's COM port settings (see VIII). Check that you are uploading the correct file (with .BIN extension). Try to perform an update on a slower baud rate, e. g. 4800 baud.

APPENDIX B. Configuration Presets

Preset #1

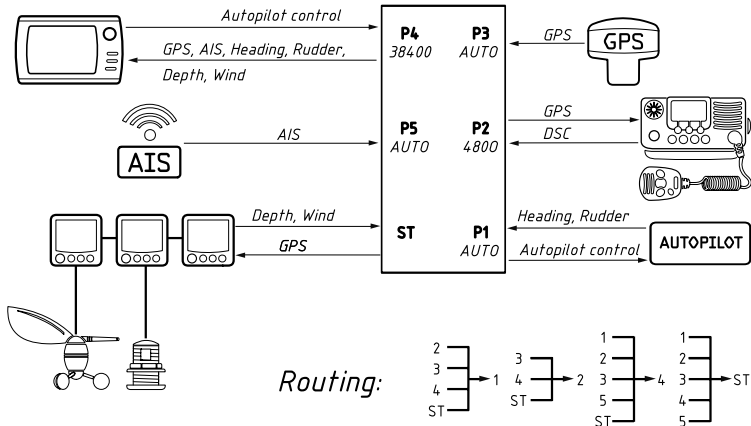

This preset requires an autopilot (or other equipment on Port #1) which regularly sends NMEA 0183 data. The Multiplexer will not send data to Port #1 (configured for automatic detection of port speed) until it can determine the port speed by receiving data on the input.

Note that Port #2 is configured to filter out outgoing AIS messages (VDO and VDM) in all presets (see VI.2). Other ports have no filters and pass all messages in all directions.

Preset #2

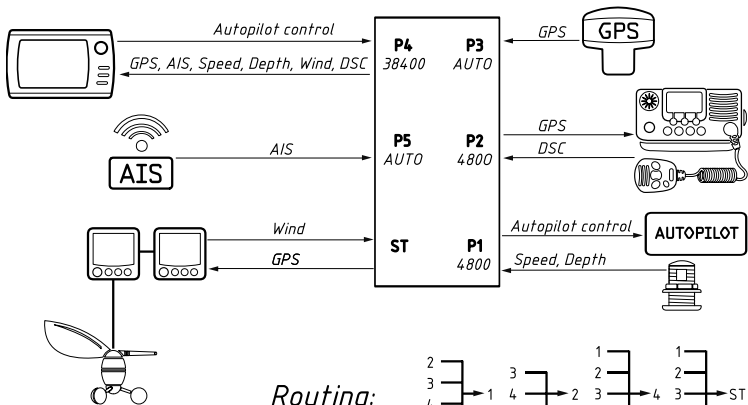

This preset differs from preset #1 only by fixed speed (4800 baud) of Port #1. It allows to use Port #1 if no talker is connected (see notes of preset #1 for details) or talker can be switched off.

Note that Port #2 is configured to filter out outgoing AIS messages (VDO and VDM) in all presets (see VI.2). Other ports have no filters and pass all messages in all directions.

Preset #3

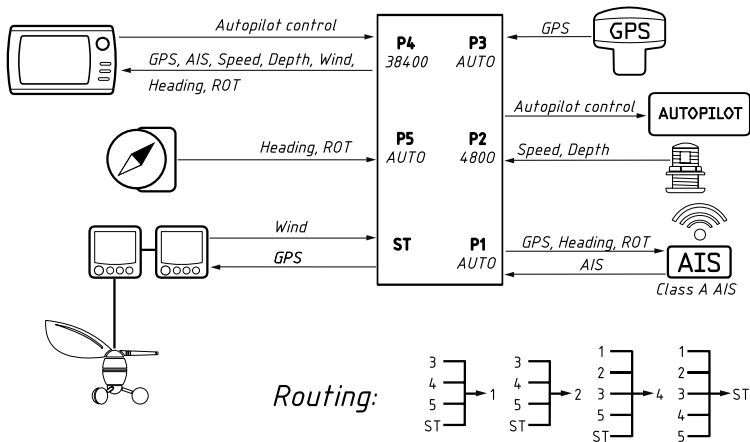

This preset differs from preset #1 by routing to Ports #1 and #2 only. It can be used to simultaneously supply AIS Class A transceiver and a chart plotter with a data from multiple NMEA 0183 and SeaTalk sources.

Preset #4

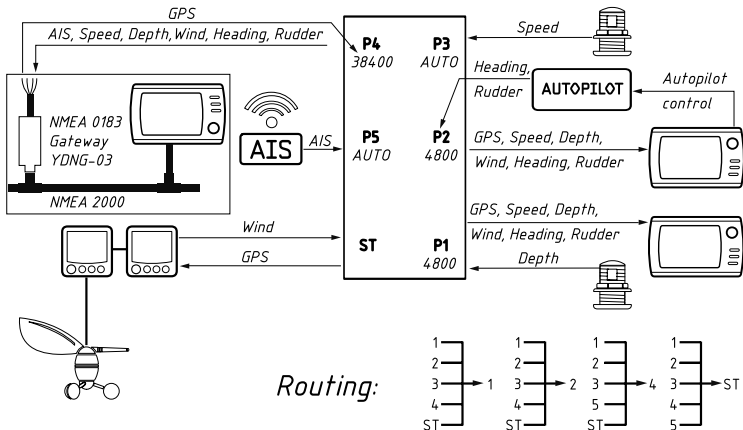

This preset shows a possibility to connect the Multiplexer to an NMEA 2000 network with Yacht Devices NMEA 0183 Gateway YDNG-03. It differs from preset #2 in routing of Port #1 and Port #2. These ports forward received messages to self, this allows connecting of the Multiplexer in line with two Devices and to enrich the data stream with data from other ports (see VI.1).

Preset #5

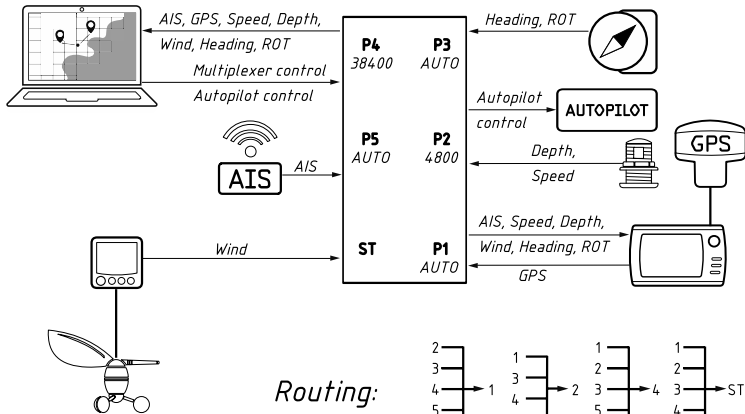

Routing:

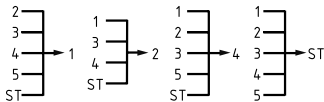

This preset shows the option to connect the Multiplexer to a laptop or PC with navigation software in parallel with NMEA 0183 chart plotter. The PC may have an AIS stick connected (USB AIS receiver). The low-speed Port #2 is protected from being flooded by AIS messages by filters (see VI.2). Connect the PC to the isolated Port #4 only to avoid possible different ground potential issues.

Port #4 in this preset can also be used to connect gateway to NMEA 2000, for example Yacht Devices NMEA 0183 Gateway YDNG-03.

Preset #6

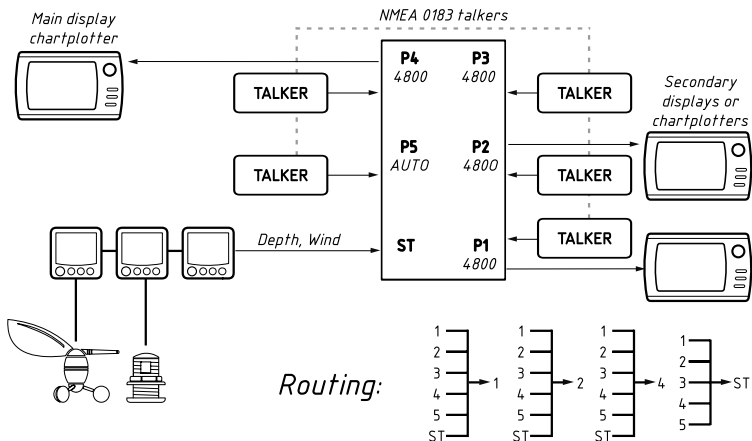

This preset can provide data from the SeaTalk network and from up to 5 different NMEA 0183 talkers (e.g. GPS, speed transducers and other NMEA 0183 sensors which has a 4800 baud rate output) to up to 3 listeners (chart plotters or informational displays) with 4800 bps inputs.

APPENDIX C. Conversions Between SeaTalk and NMEA 0183

From SeaTalk Datagrams	NMEA 0183 Sentence	To SeaTalk Datagrams	Comment
Any	ALK	Any	Raw SeaTalk data (\$STALK sentence)
85 A2	APB	82 85 9E A1 A2	Heading/Track Controller Sentence «B» (Autopilot)
82 85 A1	BWC	82 85 9E A1	Bearing & Distance to Waypoint – Great Circle
—	BWR	82 85 9E A1	Bearing & Distance to Waypoint – Rhumb Line
00	DBT	00	Water Depth
00	DPT	00	Water Depth
50 51 58	GLL	50 51 58	Geographic Position – Latitude/ Longitude
89 (99)	HDG	89 99	Heading and Variation
89	HDM	89	Heading, Magnetic
89 (99)	HDT	89	Heading, True
23 27	MTW	23 27	Water Temperature
10 11	MWV	10 11	Wind Speed and Angle
85 A2	RMB	82 85 9E A1 A2	Recommended Minimum Navigation Information (Autopilot)
50 51 58	RMC	50 51 58 52 53 54 56 99	Recommended Minimum Specific GNSS Data
05	RPM	05	Engine Revolutions (three engines supported)
84 9C	RSA	9C	Rudder Sensor Angle

Table continued

20 26 84 89 9C (99)	VHW	20 26 89 9C 99	Water Speed (STW) and Heading
21 22 25	VLW	21 22 25	Trip and Total Distance
(52) 53	VTG	52 53 99	Course Over Ground & Ground Speed
9E A1	WPL	9E A1	Waypoint Location
85	XTE	85	Cross-Track Error (Autopilot)
54 56	ZDA	54 56	Time & Date

Note : (XX) means that the datagram does not cause sending of an NMEA sentence, but data from this datagram are used or required.

